

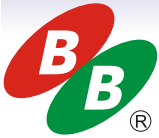

Measures Technology Values Innovation



VRLA Rechargeable Battery

UPS12320W

Standard Type

FEATURES

- Maintenance free(no water topping-up required)
- No free acid(Non-spillable battery)
- Can be used in any orientation(excluding used inverted)
- The battery is designed with very lower resistance and exceeding high power performance.
- Its design life is 10 years in floating application at 68°F/20°C
- Flame-arrestor is installed to ensure safety

APPLICATION

- UPS
- Cable TV
- Telecom
- Power station
- Golf-Carts
- Marine

SPECIFICATIONS

Nominal Voltage	12V	
Nominal Capacity	10 Hour Rate (7.8A, 10.5V)	78.0 Ah
	5 Hour Rate (13.6A, 10.5V)	68.0 Ah
	1 Hour Rate (55.3A, 9.6V)	55.3 Ah
	15 Min Rate (320W, 9.6V)	40.0 Ah
Approx. Weight	26.0Kg(57.3lbs.)	
Terminals	B5 (Fitting M6 bolt & nut) I2 is optional	
Max. Discharge Current	800 A (5 sec.)	
Max. Charge Current	23.4 A	
Cold Cranking Amp @ -18°C	700 A	
Short Circuit Current	2300 A	
Operating Temperature Range	Charge	0°C~50°C(32°F~122°F)
	Discharge	-20°C~60°C(-4°F~140°F)
	Storage	-20°C~50°C(-4°F~122°F)
Self Discharge	< 3% per month (25°C)	
Internal Resistance	≤ 4mΩ (Fully Charged)	



CONTAINER MATERIAL

- UPS12320W:
- PP: UL 94-HB

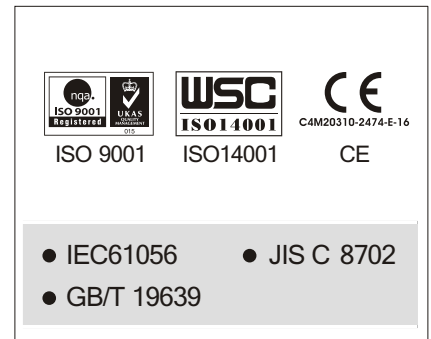

OUTER DIMENSIONS mm(inch)	Length (L)	Width (W)	Container Height (H)	Total Height (TH)
	261±2.0(10.28±0.08)	173±2.0(6.81±0.08)	200±2.0(7.87±0.08)	224±2.0(8.82±0.08)

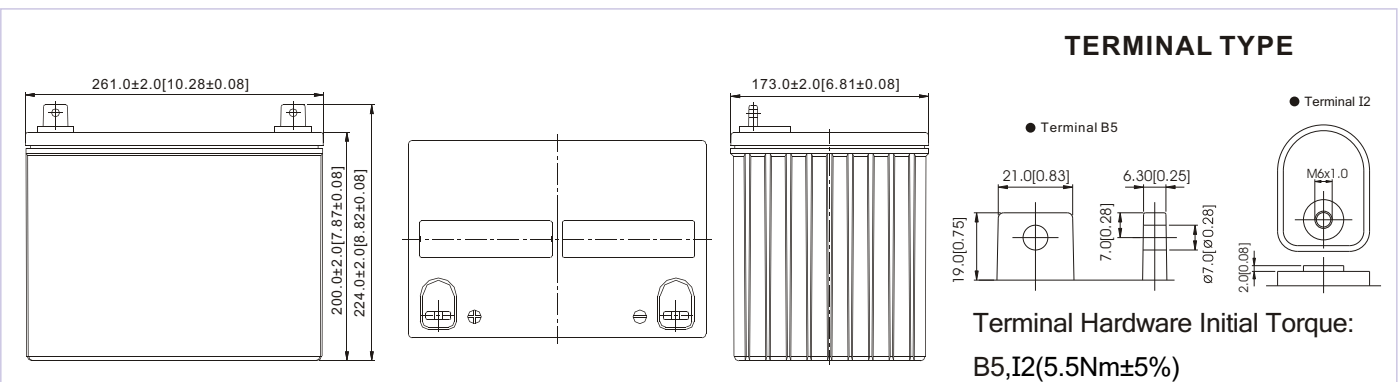

UPS12320W Charging Characteristics

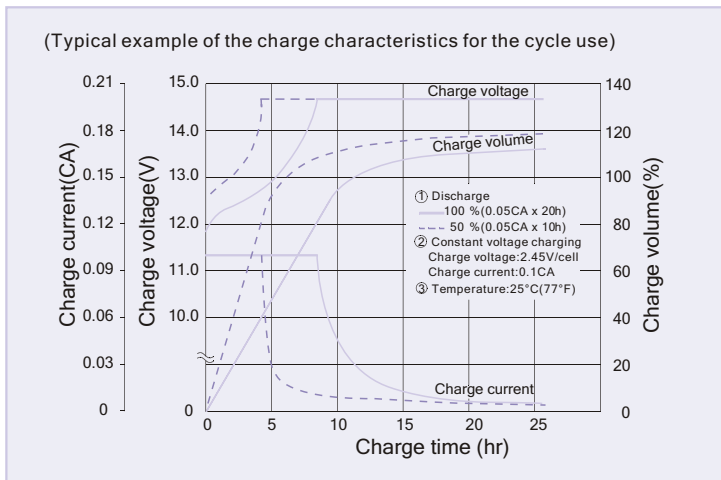

Battery Charging Characteristics

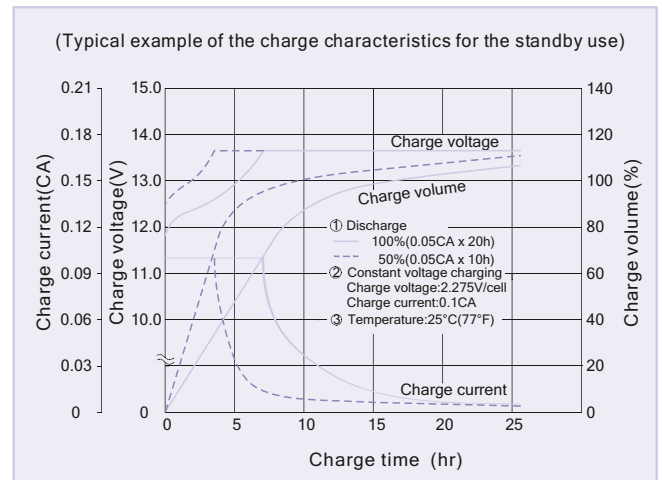

Charging Procedure

Application	Charging method	Charging Voltage at 25°C (V/cell)	Temperature compensation coefficient of charging voltage (mV/°C /cell)	Max. charging current (CA)	Charging time 0.1CA, 25°C (h)		Temp (°C)
					100% discharge	50% discharge	
For standby power Source	Constant voltage & Constant current charging (with current restriction)	2.25~2.30	-3	0.3	24	20	0~50 (32~122°F)
For cycle service		2.40~2.50	-4	0.3	16	10	

Effect Of Temperature On Long Term Float Life

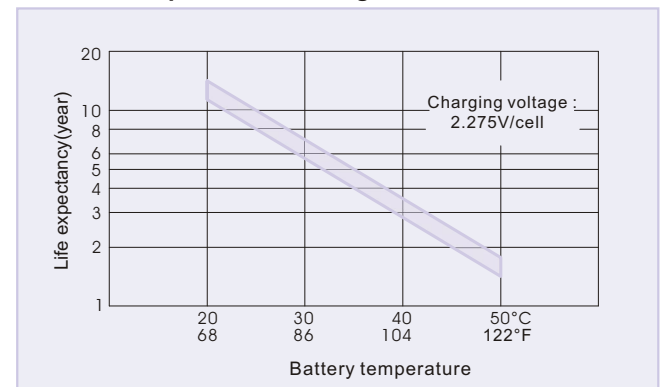

Constant power discharge characteristics at 25 °C/77 °F Unit: W

F.V. (V/cell) \ Discharge Time	5 Min	10 Min	15 Min	20 Min	25 Min	30 Min	40 Min	50 Min	60 Min	90 Min
1.80V	2771	2036	1692	1413	1225	1075	864	727	629	447
1.75V	3105	2184	1790	1468	1263	1104	883	743	640	455
1.70V	3312	2277	1847	1505	1287	1121	896	752	648	460
1.65V	3450	2348	1891	1535	1307	1134	907	759	654	464
1.60V	3549	2391	1920	1556	1324	1145	916	765	659	467

Constant current discharge characteristics at 25 °C/77 °F Unit: A

F.V. (V/cell) \ Discharge Time	5 Min	10 Min	15 Min	20 Min	25 Min	30 Min	40 Min	50 Min	60 Min	90 Min
1.80V	258	179	147	121	103	90	72	61	52.9	37.7
1.75V	283	193	155	126	108	93	74	62	53.8	38.3
1.70V	301	201	160	129	111	95	75	63	54.4	38.7
1.65V	313	207	164	132	112	96	76	64	54.9	39.0
1.60V	323	211	167	134	113	97	77	64	55.3	39.3

All data shall be changed without prior notice, BB reserves the right to explain and update the information contained hereinto.

A/0 REV. Oct. 2009

USA:
 B&B BATTERY(USA) INC.
 6415 RANDOLPH ST.COMMERCE, CA,90040 U.S.A.
 TEL:1-323-278-1900.1-800-278-8599
 FAX:1-323-278-1268
 E-Mail:sales@bb-battery.com

CHINA FACTORY:
 B. B. BATTERY CO., LTD.
 CHENG DONG TRIAL AREA,HUANG GANG,
 RAOPING, GUANG DONG,CHINA,515700
 TEL:86-768-7601001-2
 FAX:86-768-7601469
 E-Mail:maggy@bb-battery.com

EUROPE:
 B&B BATTERY(EUROPE) B.V.
 LAAN VAN KRONENBRUG 8, 1183AS
 AMSTELVEEN, THE NETHERLANDS
 TEL: +852-91282711
 MOBILE: +852-91282711
 E-Mail: dliu@bb-battery.com

HONG KONG:
 NATIONAL TRADING LTD.
 TEL:852-2301-3800
 FAX:852-2739-1182
 E-Mail:bbhk@hkstar.com

JAPAN:
 B&B BATTERY(JAPAN) CO., LTD.
 1375-11 NARAHARA-MACHI,HACHIOJI,
 TOKYO 193-0803,JAPAN.
 TEL:81-426-25-6375
 FAX:81-426-25-6375
 E-Mail:miyata@bb-battery.com

TAIWAN:
 B. B. BATTERY(TAIWAN) CO., LTD.
 TEL:886-6-502-5150
 FAX:886-6-589-8087
 E-Mail:maggy@bb-battery.com